



W60 - 0



# APU®

PROFILES FOR COMPOUND HEAT INSULATION SYSTEMS

## Stick-on profile

# ZERO

With drip edge and 12.5 cm mesh

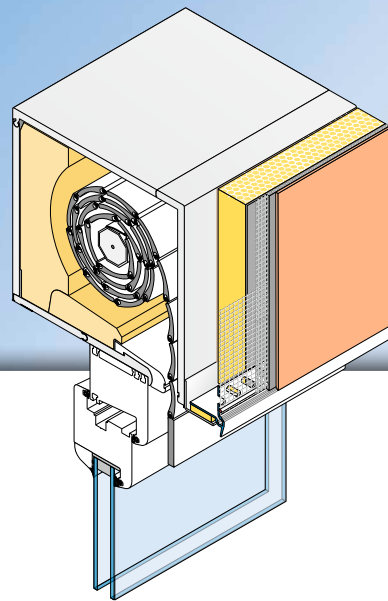

The **APU stick-on profile ZERO** is used horizontally in compound heat insulation systems e.g., for plaster joints up against shutter boxes.

The profile contour with visible drip edge provides a reliable solution in respect of downward guidance of water.

The profile has a punched plaster bar. Welded onto the plaster limb is a fabric strip.

Each bar has a fabric overhang on one side of 10cm in the lengthways direction. The lower limb is fitted with PE foam tape for sticking the profile to the respective surface. The included plug connectors (Z13) and inner and outer corners (Z18-0) enable the profiles to be joined and fitted very precisely. What is created after completion of the plastering work is a clean termination of the plaster.



## Fitting

- 1 The sub-surface must be even, dry, free of dust and suitable for the profile to be stuck on permanently. Any residues that would impair adhesion must be removed.
- 2 Above the insulation material edge, apply across the full area c.  
15 cm of reinforcement base plaster up to the material's edge.
- 3 Using trimming shears with supporting surface, cut profile to the desired size.
- 4 Stick profile in flush alignment onto the existing structural component.
- 5 Join the subsequent profiles with the enclosed plug connectors (Z13).
- 6 Form inside and outside corners using the (Z18) corner connectors provided.
- 7 Apply reinforcement base plaster, mesh and final render. The surface mesh must be run up to the skimming edge.

## Important information

- Any applications not clearly described in the documents may be implemented only after consultation with the plaster or ETICS manufacturer.
- When the work is being done, the surface temperature must be at least +5 degrees and must not exceed +40 degrees.
- After being set in place on the structural element, profiles with a mesh vane must be promptly embedded. Until then they must be protected from the weather.
- The mesh vane and surface mesh must overlap by at least 10 cm. The surface mesh must be run up to the skimming edge of the profile.
- The processing guidelines of the plaster manufacturer shall be complied with.